



MULTI SCREEN® MS 1000



1,8 t

ON A GREEN MISSION

soil



green waste



wood chips



sand & gravel



recycling



compost





MULTI SCREEN® MS 1000

OPTIONS



Special lacquering



Ripped belt



Petrol power generator



External wire screens
optional
2 to 80 mm



MULTI SCREEN® MS 1000

TECHNICAL DESCRIPTION

Base frame:

chassis: rubber suspension single axle
 tires: 2 x 195/70 R13C,
 load capacity each 900 kg
 brake: braking axle VGB 18-MV

Feeder:

cubage: approx. 1 m³
 loading height: 2,000 mm
 loading length: 2,350 mm

Feeding belt:

belt width: 650 mm
 belt length: 2,000 mm
 belt type: smoother belt
 belt speed: dispatchable
 profiled belt: possible

Single trommel:

surface: 3 m² (outer screening)
 diameter: 900 mm
 length: 1,500 mm
 speed: 18 U/min
 drive: smooth start, not adjustable
 direct over belt pulleys

Cleaning brush:

diameter: 350 mm, self regular

Power:

electric drive (16A)
 power input approx. 5 kW (6,5 kVA) (standard)
 optional: petrol power generator 6,4 kW
 (not included)

Prime power: 5,6 kW

Tank capacity: 6,6 l

Weight: 79 kg

Measures: 770 x 520 x 650 mm

For MS 1000 without additional electrical load

Weight: max. 1,800 kg

Hitch:

Trailer hitch ball Ø 50 mm according ISO24347

Dimensions:

Transportation:

length: 4,800 mm
 width: 1,900 mm
 height: 2,200 mm

Operation:

length: 4,800 mm
 width: 2,900 mm
 height: 2,200 mm

Conveyor belt fine fraction:

belt width: 800 mm
 belt length: 1,760 mm
 belt type: smooth belt, mechanic fold-away
 drop off side: left
 drop off height: 1,400 mm

Capacity:

5 - 20 m³/hour
 depending on condition of material,
 mesh size and feeding

2 fractions:

fine fraction: 2 - 80 mm, on demand
 coarse fraction: up to a maximum 200 mm (standard)

Screen material:

sand, saw dust, wood chips, compost and recycling
 materials, stones and gravel sand

Colour / Coats:

polyurethane one-coat topcoat
 silo, engine cover and side covers:
 RAL 6001 green
 chassis, screening drum:
 RAL 7022 umbra grey
 conveyor belt frame:
 hot galvanized



MULTI SCREEN® MS 1000

DIMENSIONS

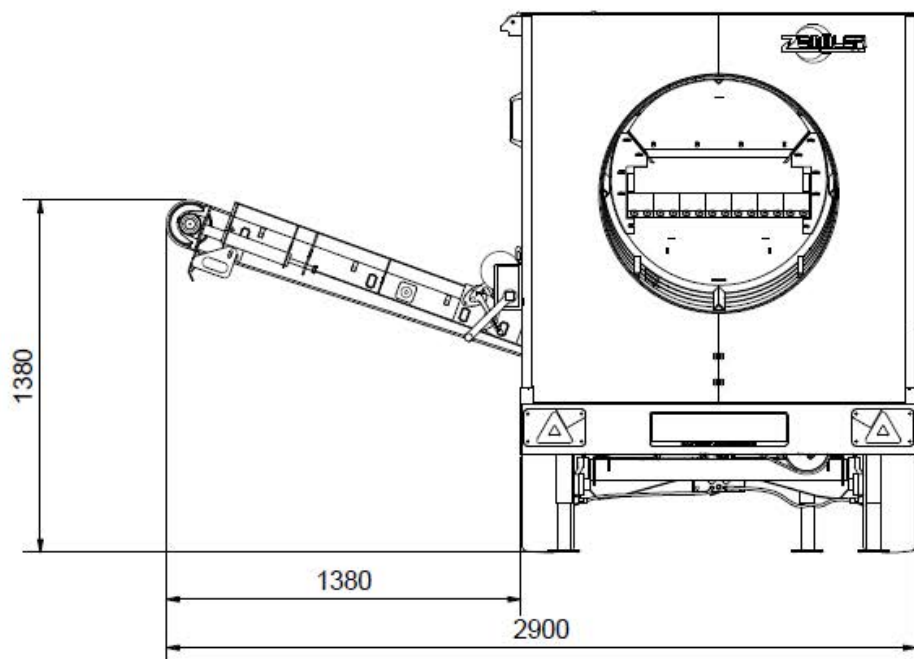
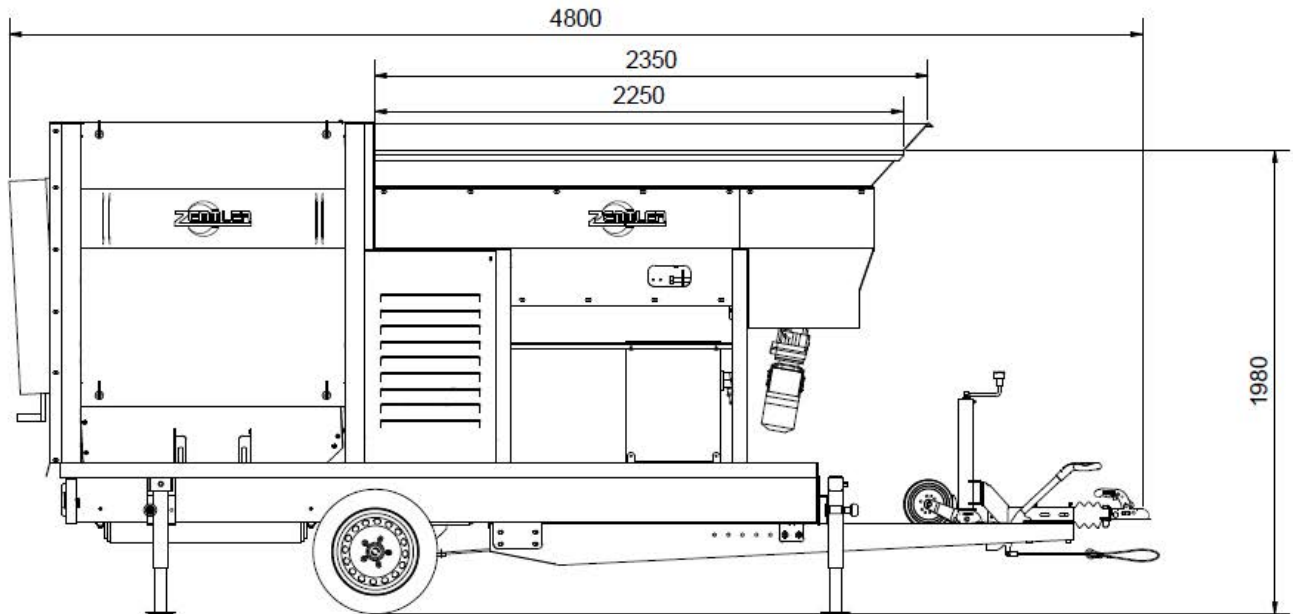



MULTI SCREEN® MS 1000

DIMENSIONS TRANSPORTATION

