



# MULTI SCREEN® MS3200



## ON A GREEN MISSION

soil



construction waste



green waste



wood chips



sand & gravel



recycling



stones



compost





# MULTI SCREEN® MS3200

## OPTIONS



Bisection of the inner trommel approx. 75 x 75 mm



Outer wire screens 2 to 80 mm



Inner wire screens optional 40 to 80 mm



Remote control

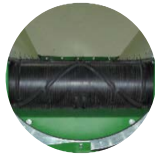

Ripped belt for feeder or fine fraction



Foldable hopper walls



Chute for 3rd fraction



Extension for feeder



Extended conveyor belts

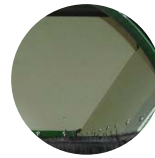

Abrasion plates for the silo



Rear conveyor belt for coarse fraction

## MORE OPTIONS



Extension for 3rd fraction; punched  $\varnothing 40$  /  $\varnothing 50$  mm or not-punched



Remodeling on skids



Remodeling to hook lift



External power supply



Arbeitsscheinwerfer



Diesel power generator 17,0 kVA 14,4 kW



# MULTI SCREEN® MS3200

## TECHNICAL DESCRIPTION 1

### ■ Base frame:

longitudinal beam: hollow profile, height 180 mm  
 chassis: 2 x 5,5 t Leaf spring axles by  
 product: Gigant  
 tires: 4 x 235/75 R17.5  
 rim: 4 x 6,75 x 17.5  
 brake: drum air break EBS-control unit  
 (ABS)

### ■ Feeder:

cubage: approx. 2,3 m<sup>3</sup>  
 loading height: 2,515 mm  
 loading length: 3,050 mm

### ■ Feeding belt:

belt width: 800 mm  
 belt length: 2,770 mm  
 belt type: plain  
 speed: adjustable  
 profile belt optional

### ■ Double trommel:

surface:  
 inner: 8.1 m<sup>2</sup>  
 outer: 10.0 m<sup>2</sup>  
 trommel diameter: 1,000 mm (inner)  
 trommel diameter: 1,300 mm (outer)  
 trommel length: 3,000/ 3,900 mm

trommel drive: direct over chain and  
 chain wheel

### ■ Mesh sizes:

inner: 75 x 170 mm (standard)  
 outer: exchangeable wire screens,  
 2 - 80 mm  
 screen change function by means of remote  
 control

### ■ Cleaning brush:

diameter: 350 mm, with own drive

### ■ Conveyor belt fine fraction:

belt width: 600 mm  
 Y-profile belt  
 mechanic foldable  
 drop off side: left  
 drop off height: 1,970 mm (standard)  
 2,775 mm (extended conveyor belt)

### ■ Conveyor belt middle / coarse fraction:

belt width: 600 mm  
 Y-profile belt  
 mechanic foldable  
 drop off side: right  
 drop off height: 2,010 mm (standard)  
 2,650 mm (extended conveyor belt)

### ■ Conveyor belt beneath double drum, Fine fraction

belt width: 800 mm  
 belt length: 4,500 mm

### ■ 2 fractions:

fine fraction: 2 - 80 mm, on demand  
 coarse fraction: ex 170 mm (standard)  
 3rd fraction: optional by extension

### ■ Screen material:

sand, saw dust, wood chips, compost, soil, glass,  
 coal and cinder, construction waste and recycling  
 materials, stones and gravel sand



# MULTI SCREEN® MS3200

## TECHNICAL DESCRIPTION 2

### Chassis options:

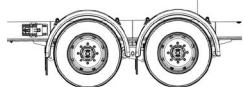

On wheels (standard)



Track drive  
(requires remote control Maxi)



On skids



Hook lift

### Power:

electric drive (32A)  
approx. 12,7 kW / 15,9 kVA (standard)  
optional diesel-power-generator 17 kVA  
(not included in the basic price)

### Additional hydraulic options:

Standard conveyor belt  
Rear conveyor belt for coarse fraction  
extended conveyor belt for fine fraction  
extended conveyor belt for coarse fraction

### Weight:

approx. 7,600 kg  
(standard equipped machine)

### Hitch:

height adjustable,  
drawbar eye Ø 40 mm or Ø 50 mm

### Dimensions:

#### Transportation:

|                  |                    |
|------------------|--------------------|
| Standard         | ext. conveyor belt |
| length: 8.976 mm | 9.001 mm           |
| height: 3.580 mm | 3.640 mm           |
| width: 2.425 mm  | 2.448 mm           |

#### Service:

|                  |                    |
|------------------|--------------------|
| Standard         | ext. conveyor belt |
| length: 8.976 mm | 9.001 mm           |
| width: 6.624 mm  | 10.136 mm          |
| height: 3.580 mm | 3.640 mm           |

### Capacity:

up to 60 m<sup>3</sup>/hour,  
depending on condition of  
material, mesh size and feeding

### Colour / Coats:

polyurethane one-coat topcoat  
silo, engine cover and side covers: RAL 6001 green  
chassis, screening drum: RAL 7022 umbra grey  
conveyor belt frame: hot galvanized



# MULTI SCREEN® MS3200

## DIMENSIONS STANDARD EQUIPPED

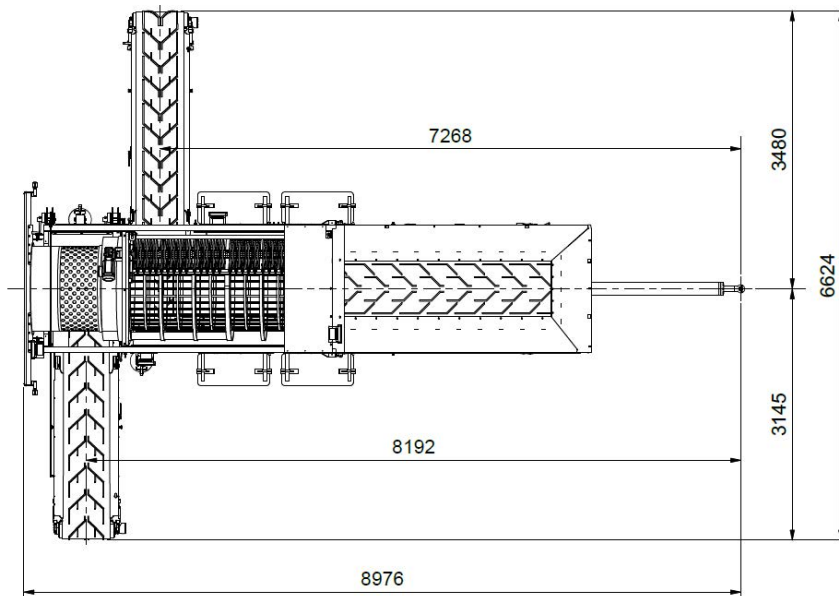
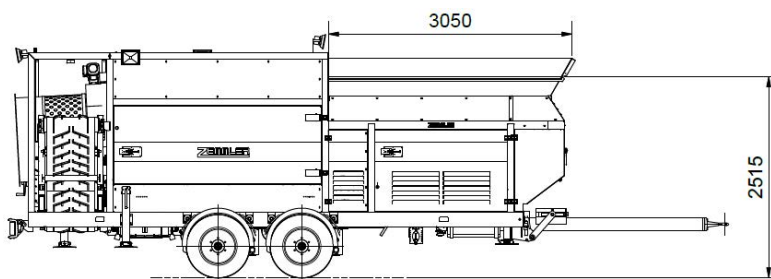
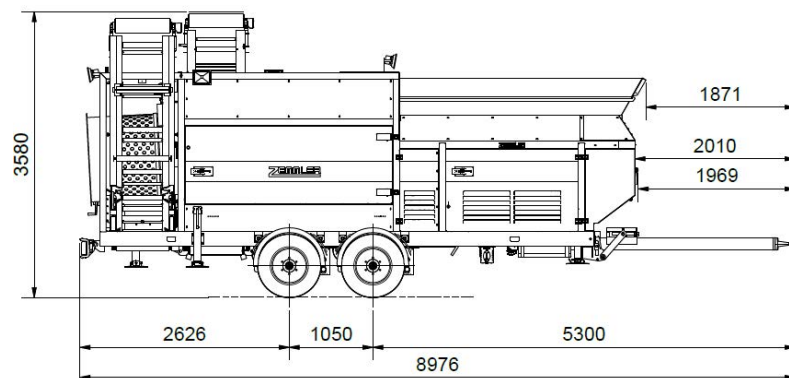



# MULTI SCREEN® MS3200

## DIMENSIONS STANDARD EQUIPPED

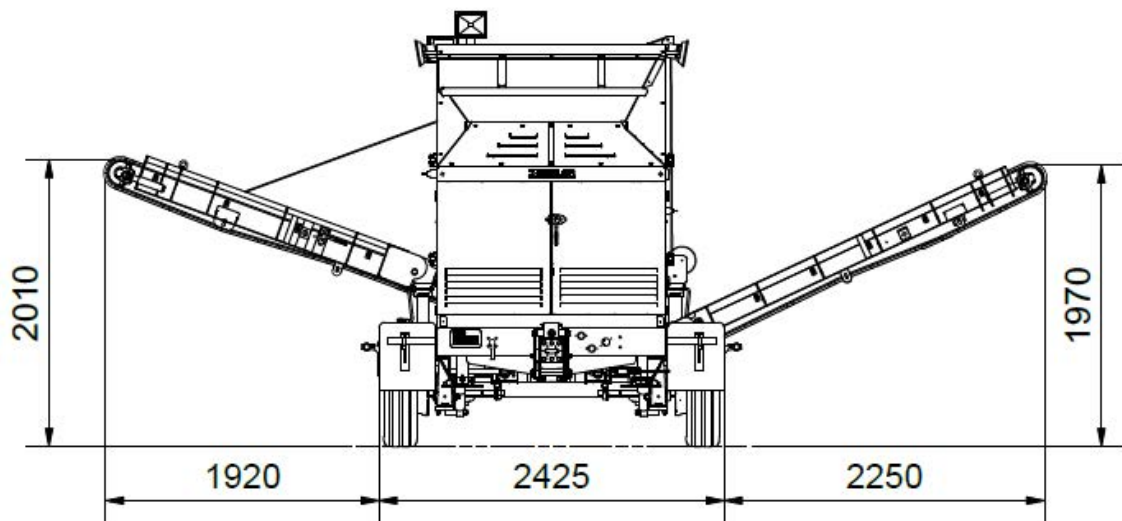
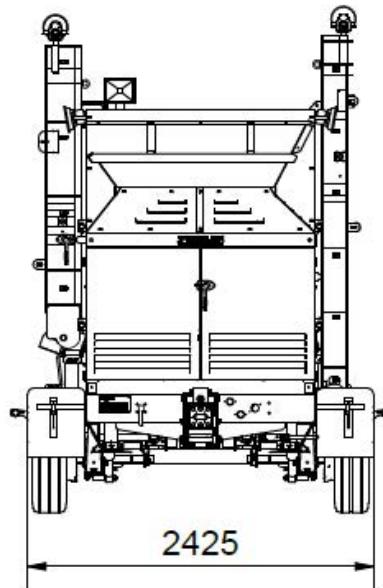





# MULTI SCREEN® MS3200

## DIMENSIONS EXTENDED CONVEYOR BELTS

