



Horquilla portapalets para cargadora compacta





Horquilla portapalets para cargadora y retrocargadora



HORQUILLA PORTAPALETES

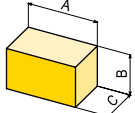

CARACTERÍSTICAS TÉCNICAS

Modelo	um	Cargadora compacta				Cargadora y retrocargadora		
		PF 100	PF 120	PF 130	PF 150	PF 250	PF 450	
Capacidad de elevación ⁽¹⁾ Q	kg	1000		1800	2500	2500	4500	
Peso dotación estándar	kg	120	145	185	230	260	380	
Sección horquilla ExF	mm	80x30		100x35	100x40	100x40	120x50	
Longitud de horquillas C	mm	1000		1100	1200	1200		
Ancho chasis L	mm	1000	1200	1300	1500	1500		
Altura chasis H	mm	900	950		450		540	
Centro de gravedad B	mm	500				500		
	t	1,3 - 1,6	1,6 - 2,6	2,6 - 3,5	3,4 - 4,8	---	---	
	t	---	1,5 - 3,0	2,8 - 4,0	---	4,0 - 6,2	6,0 - 12,0	
	t	---	2,0 - 3,4	3,0 - 4,6	---	4,5 - 6,5	6,2 - 9,0	
Dimensiones de la máquina sin accesorios		A cm	100	120	130	150	150	150
	B cm	90	95	95	95	54	54	54
	C cm	110	121	131	141	124	125	125

⁽¹⁾ La elevación máxima "Q" se refiere a una carga de gravedad "B" centrada sobre ambas horquillas.

Dimensiones de trabajo

Horquilla portapalets para cargadora compacta

Horquilla portapalets para cargadoras y retrocargadoras

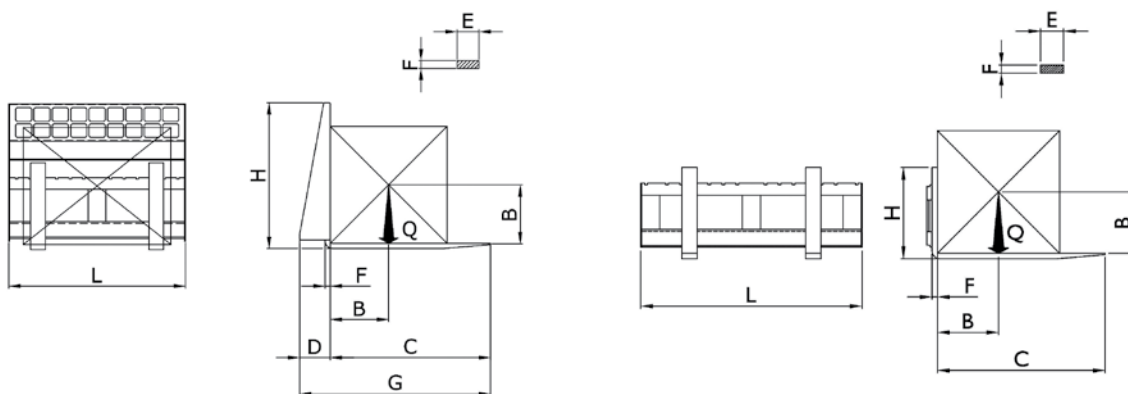

G.F. Gordini srl

Via E. Mattei, 4 - 48012 Bagnacavallo RA - Italy

tel. +39 0545 62712 fax +39 0545 62140

info@gfgordini.com - www.gfgordini.com

ACCESSORI PER MACCHINE OPERATRICI

Los datos y las imágenes contenidas en la Ficha Técnica son sólo indicativos, por lo tanto, GF Gordini srl se reserva el derecho de realizar cualquier modificación de los productos sin previo aviso