



We Build Solutions



www.tabe-hammers.com

PT 100
PT 195
PT 200

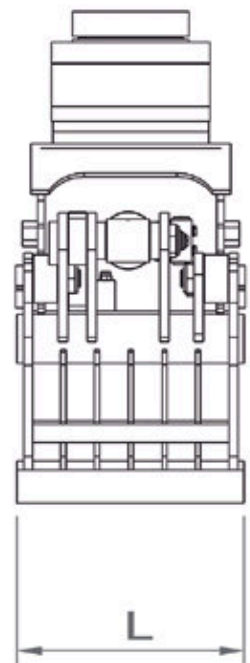
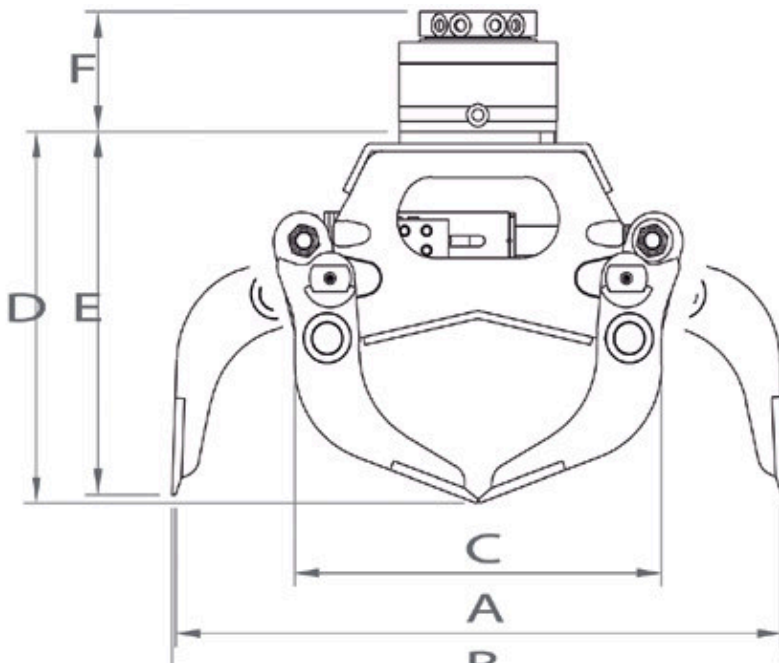

Modelo	A	B	C	D	E	L	F	Fuerza a la lama
	mm	mm	mm	mm	mm	mm	mm	kg
PT 100	675	700	490	380	360	300	270	1150
PT 195	970	1000	670	600	580	370	integrado	2320
PT 200	970	1000	670	600	580	370	integrado	2320

PT 300
PT 400
PT 450

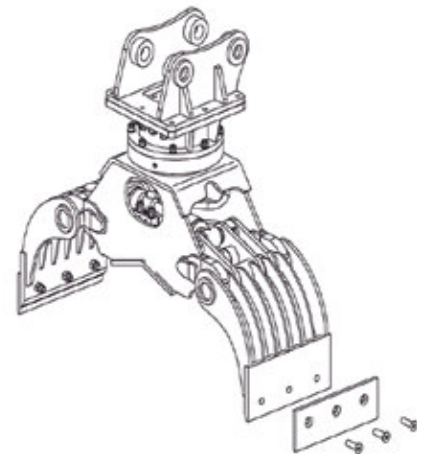
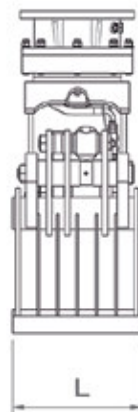
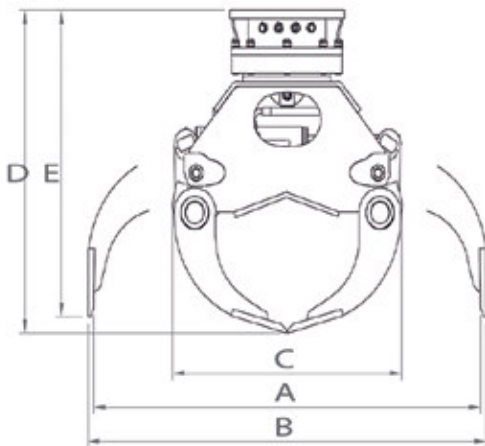

Modelo	A	B	C	D	E	L	Capacidad	Fuerza a la lama
	mm	mm	mm	mm	mm	mm	dm ³	kg
PT 300	1350	1400	800	950	900	450	100	2500
PT 400	1800	1840	1110	1180	960	600	220	3300
PT 450	1800	1840	1110	1180	960	700	260	3300

PT 500
PT 600
PT 800

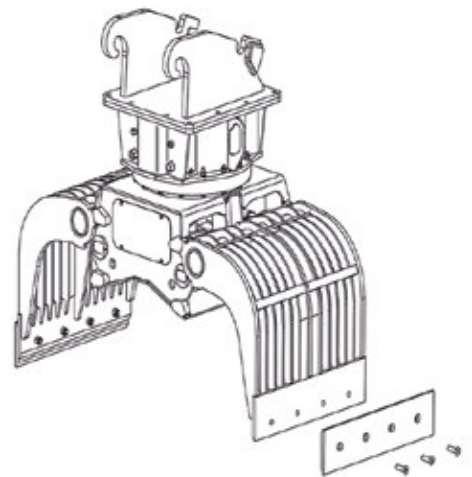
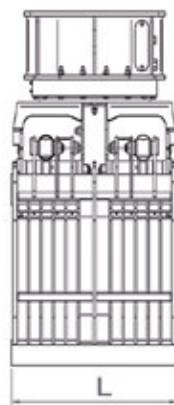
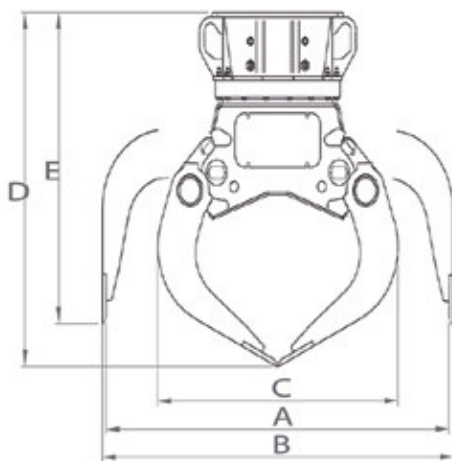

Modelo	A	B	C	D	E	L	Capacidad	Fuerza a la lama
	mm	mm	mm	mm	mm	mm	dm ³	kg
PT 500	1760	1800	1230	1400	1230	850	500	4100
PT 600	1760	1800	1230	1400	1230	1000	600	4100
PT 800	2000	2060	1360	1620	1440	1000	800	5600

PT 1000
PT 1150
PT 1300

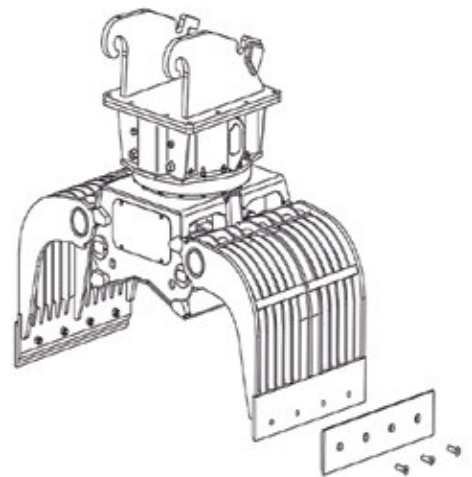
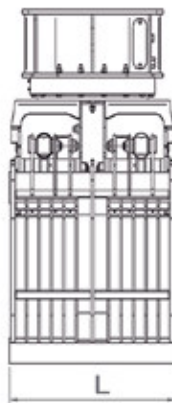
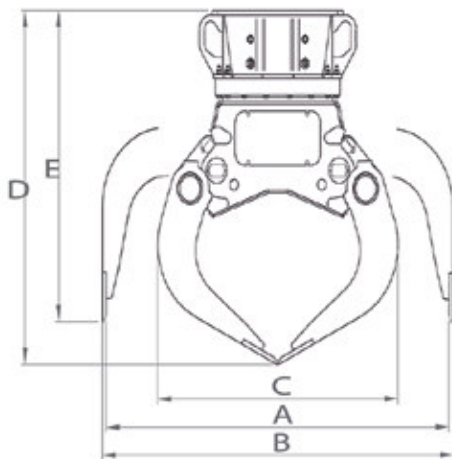

Modelo	A	B	C	D	E	L	Capacidad	Fuerza a la lama
	mm	mm	mm	mm	mm	mm	dm ³	kg
PT 1000	2200	2280	1490	1740	1490	1000	1000	5050
PT 600	2200	2280	1490	1740	1490	1150	1150	5050
PT 800	2200	2280	1490	1740	1490	1300	1300	5050